



B404B Plug-in Detector Base

For use with 1451, 2451, AND 2451TH detectors

3825 Ohio Avenue
St. Charles, Illinois 60174
1-800-SENSOR2, FAX: 630-377-6495

Specifications

Base Diameter:	6.2 inches (15.7 cm)
Base Height:	0.95 inches (2.9cm)
Weight:	0.6 lb. (260 g)
Mounting:	4-inch square box with or without plaster ring. Min. depth-1.5 inches 4-inch octagon box. Min. depth-1.5 inches 3½-inch octagon box. Min. depth-1.5 inches
Operating Temperature Range:	0° to 49°C (32° to 120°F)
Operating Humidity Range:	10% to 93% Relative Humidity

Electrical Ratings - includes base and detector

System Voltage:	120 VAC, 60 Hz
Relay Contact Ratings	
Resistive or Inductive (60% power factor) load	
Form A:	2.0A @ 30VAC/DC
Form C:	2.0A @ 30VAC/DC 0.6A @ 110VDC 1.0A @ 125VAC

(If used, the RA400 Remote Lamp operates within the specified detector system voltage.)

Start-up Time:	36.0 Seconds maximum
----------------	----------------------

(After 60 second reset)

Before Installing

Please thoroughly read the System Sensor manual I56-407, *Guide for Proper Use of System Smoke Detectors*. This manual provides detailed information on detector spacing, placement, zoning, wiring, and special applications, and is available at no charge from System Sensor. (For installation in Canada, refer to CAN/ULC-S524, *Standard for the Installation of Fire Alarm Systems* and CEC Part 1, Sec. 32.)

NOTICE: This manual should be left with the owner/user of this equipment.

IMPORTANT: The detector used with this base must be tested and maintained regularly following NFPA 72 requirements. The detector should be cleaned at least once a year.

General Description

The B404B detector base is designed for use with System Sensor model 2451 and 2451TH photoelectronic and 1451 ionization detector heads. The capability of plugging these detectors into a variety of special bases makes them more versatile than equivalent direct-wired models. Refer to the System Sensor catalog for other available plug-in bases.

The B404B base is intended for use in 4-wire systems with terminals provided for power, remote annunciator, and relay connections. This base also contains a resistor to provide current limiting in the alarm state.

Base Terminals

No.	Function
1	Remote Annunciator (+)
2	Test Coil (+)
3	Not used
4	Remote Annunciator (-)
5	RTC (-)
6	N.O. } Supervisory Relay
7	N.O. } Form A Contacts
8	N.O. } Alarm Relay
9	N.O. } Form A
10	C. } Initiation
11	C. } Contacts
12	N.O. } Alarm Relay
13	N.C. } Form C
14	C. } Auxiliary Contacts

Figure 1. Base terminals:

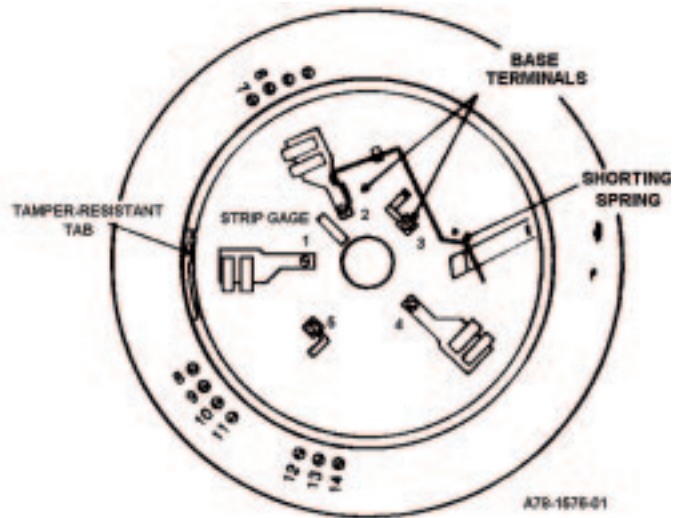

Mounting

The detector base mounts directly to 3½-inch and 4-inch octagon boxes and 4-inch square boxes, with or without plaster rings. To mount the base, remove the decorative ring by rotating it in either direction to unhook the snaps before separating the ring from the base. Use the screws supplied with the junction box to attach the base to the box through the appropriate mounting slots in the base.

Figure 2. Mounting base to box:

Position the decorative ring around the base and rotate it in either direction until the ring snaps into place (please see Figure 2).

Installation Guidelines

All wiring must be installed in compliance with the National Electrical Code, all applicable local codes, and any special requirements of the authority having jurisdiction, using the proper wire size. The conductors used to connect smoke detectors to control panels and accessory devices should be color-coded to reduce the likelihood of wiring errors. Improper connections can prevent a system from responding properly in the event of a fire.

For signal wiring (the wiring between interconnected detectors), it is recommended that the wire be no smaller than 16 gauge (1.5 square mm), and that two- or three-conductor wire be no smaller than 18 gauge (1.0 square mm). For best performance, alarm loop conductors should be installed in separate grounded conduit or shielded cable to protect the alarm loop from extraneous electrical interference.

Smoke detectors and alarm systems control panels have specifications for allowable loop resistance. Consult the control panel manufacturer’s specifications for the total loop resistance allowed for the particular model control panel being used before wiring the detector loops.

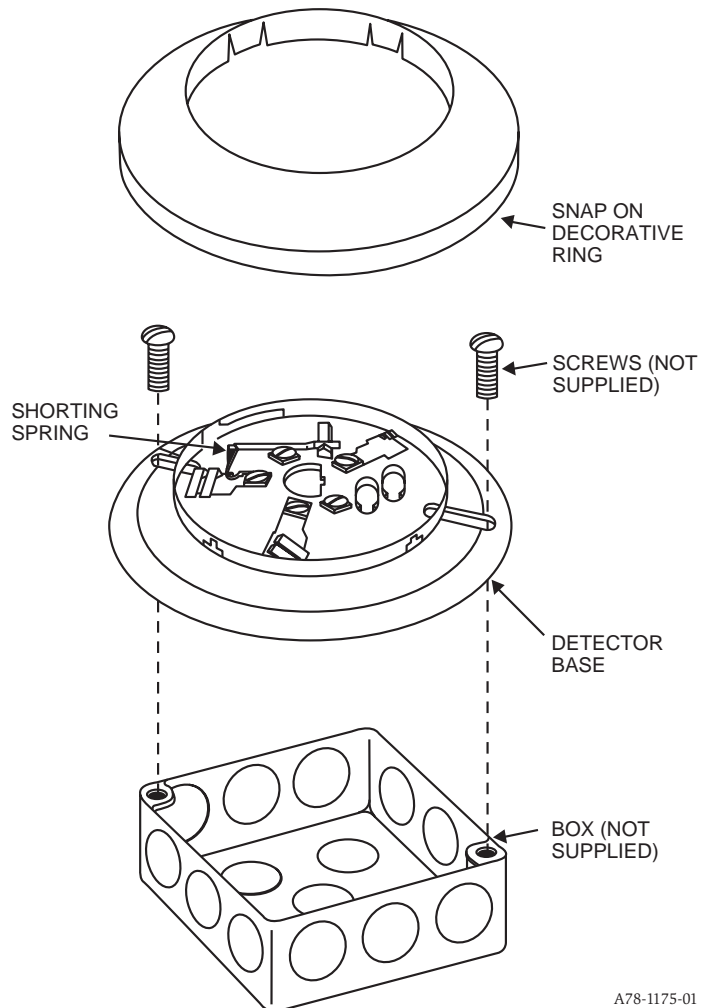
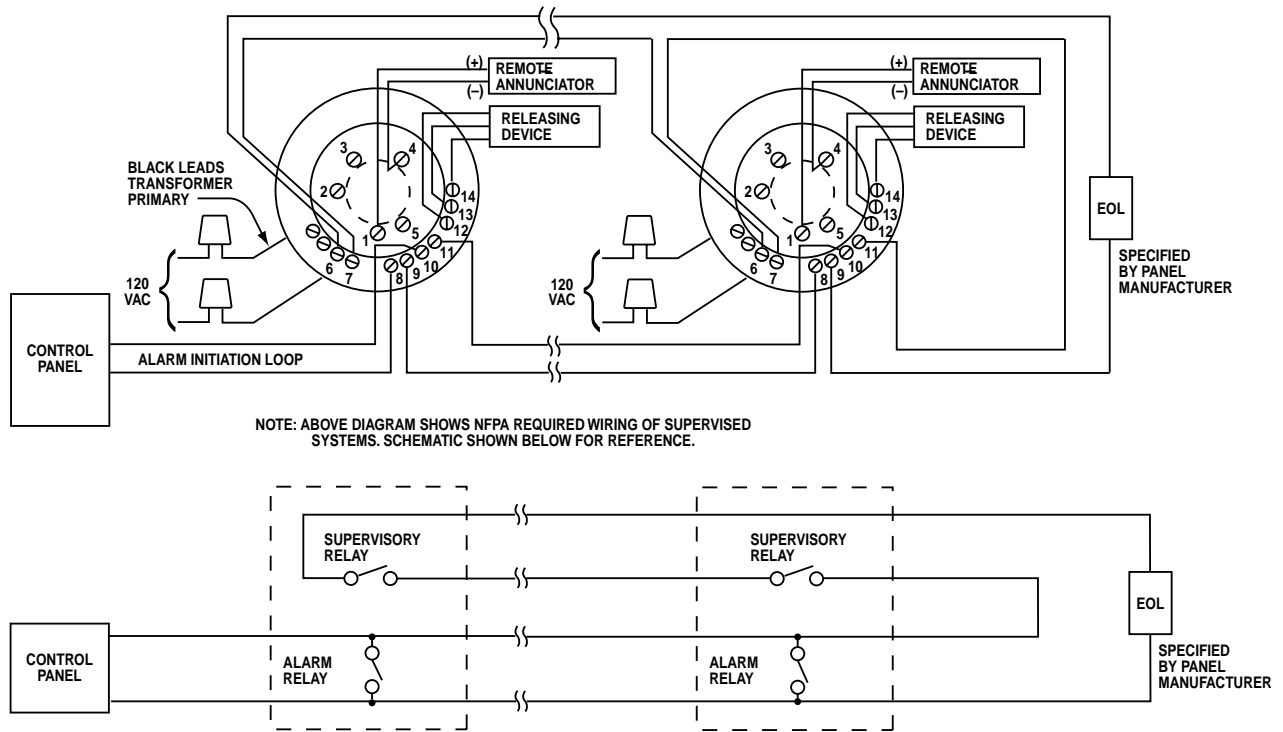

Figure 3. Typical wiring diagram for 120VAC detector systems:



Locate installations where normal ambient temperatures do not exceed 100°F.

Wiring Instructions

NOTE: Refer to the manufacturer’s instructions for releasing device wiring.

NOTE: To ensure that electrical connections are supervised, do NOT loop wires under terminals 8, 9, 10, and 11. Cut the wire at each terminal.

To make electrical connections, strip approximately 3/8" (1 cm) insulation from the end of each wire, slide the bare wire end under the clamping plate, and tighten the clamping plate screw. Use the strip gauges molded into the inside and underside of the base for ease of wiring to terminals 1 and 4, and to terminals 6 through 14, respectively.

The zone wiring of the detector base should be checked before installing the smoke detector heads. The base con-

tains a built-in shorting spring to make this possible. After the detector base is wired and mounted to an electrical box, position the shorting spring against terminal 3. This temporary connection energizes the supervisory relay and permits the wiring of the loop to be checked for continuity.

After all detector bases have been mounted, wired, and the wiring checked, install the detector heads. The shorting spring in the base automatically disengages when the detector head is removed from the base. DO NOT remove the shorting spring since it reengages as the detector head is turned into the base, completing the circuit.

Tamper-resistance Feature

This detector base can be made tamper resistant so it cannot be removed without the use of a tool. To make the base tamper resistant, simply break off the tab on the base (see Figure 4A), before installing the detector.

To remove the detector from the base after it has been made tamper resistant, insert a small screwdriver (please see Figure 4B) into the small hole and press the plastic lever away from the detector. Rotate the detector counter-clockwise and remove.

NOTE: Head removal after activating the tamper-resistance feature first requires removal of the decorative ring.

Figure 4A. Activating tamper-resistance feature:

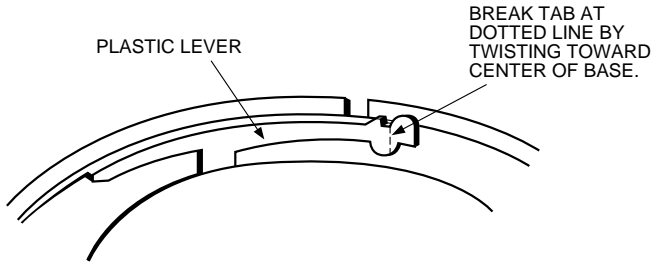
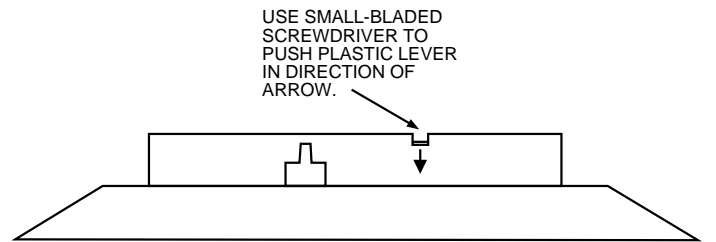

Figure 4B. Removing detector head from base:



A78-1175-03

Please refer to insert for the Limitations of Fire Alarm Systems

Three-Year Limited Warranty

System Sensor warrants its enclosed smoke detector base to be free from defects in materials and workmanship under normal use and service for a period of three years from date of manufacture. System Sensor makes no other express warranty for this smoke detector base. No agent, representative, dealer, or employee of the Company has the authority to increase or alter the obligations or limitations of this Warranty. The Company's obligation of this Warranty shall be limited to the repair or replacement of any part of the smoke detector base which is found to be defective in materials or workmanship under normal use and service during the three year period commencing with the date of manufacture. After phoning System Sensor's toll free number 800-SENSOR2 (736-7672) for a Return Authorization number, send defective units postage prepaid to: System

Sensor, Repair Department, RA # _____, 3825 Ohio Avenue, St. Charles, IL 60174. Please include a note describing the malfunction and suspected cause of failure. The Company shall not be obligated to repair or replace units which are found to be defective because of damage, unreasonable use, modifications, or alterations occurring after the date of manufacture. In no case shall the Company be liable for any consequential or incidental damages for breach of this or any other Warranty, expressed or implied whatsoever, even if the loss or damage is caused by the Company's negligence or fault. Some states do not allow the exclusion or limitation of incidental or consequential damages, so the above limitation or exclusion may not apply to you. This Warranty gives you specific legal rights, and you may also have other rights which vary from state to state.