



3825 Ohio Avenue
St. Charles, Illinois 60174
1-800-SENSOR2, FAX: 630-377-6495

B114LP Plug-in Detector Base

For use with the following smoke detectors:

IN US: 1151, 2151
IN CANADA: 1151A, 2151A
IN EUROPE: 1151E, 2151E

Specifications

Base Diameter: 6.2 inches (157 mm)
Base Height: 0.95 inches (24 mm)
Weight: 0.6 lb. (274 g)
Mounting: 4-inch square box with or without plaster ring. Min. depth-1.5 inches
4-inch octagon box. Min. depth-1.5 inches
Operating Temperature Range: 0° to 49°C (32° to 120°F)
Operating Humidity Range: 10% to 93% Relative Humidity, Noncondensing

Electrical Ratings - includes base and detector

System Voltage: 120 VAC, 60 Hz
Relay Contact Ratings
Resistive or Inductive (60% power factor) load
Form A: 2.0A @ 30VAC/DC
Form C: 2.0A @ 30VAC/DC
0.6A @ 110VDC
1.0A @ 125VAC
Start-up Time: 36.0 Seconds maximum
(After 60 second reset)

Before Installing

Please thoroughly read the System Sensor manual I56-407, *Guide for Proper Use of System Smoke Detectors*. This manual provides detailed information on detector spacing, placement, zoning, wiring, and special applications, and is available at no charge from System Sensor. (For installation in Canada, refer to CAN/ULC-S524, *Standard for the Installation of Fire Alarm Systems* and CEC Part 1, Sec. 32.)

NOTICE: This manual should be left with the owner/user of this equipment.

IMPORTANT: The detector used with this base must be tested and maintained regularly following NFPA 72 requirements. The detector used with this base should be cleaned at least once a year.

General Description

The model B114LP detector base is designed for use with System Sensor model 2151 photoelectronic and 1151 ionization detector heads. This four-wire base is equipped with screw terminals for the connection of power, ground, relay connections, and an optional RA400Z remote annunciator. It also includes a resistor that limits current when the associated smoke detector is in the alarm state.

Mounting

The detector base mounts directly to 3-1/2 inch and 4-inch octagon boxes and 4-inch square boxes, with or without plaster rings. To mount the base, remove the decorative ring by rotating it in either direction to unhook the snaps before separating the ring from the base. Use the screws supplied with the junction box to attach the base to the box through the appropriate slots in the base.

See Figure 2. Position the decorative ring around the base and rotate it in either direction until the ring snaps into place.

Base Terminals

No.	Function
1	Remote Annunciator (+)
2	Not used
3	Not used
4	Remote Annunciator (-)
5	Not used
6	N.O. Supervisory Relay
7	N.O. Form A Contacts
8	N.O. Alarm Relay
9	N.O. Form A
10	C. Initiation
11	C. Contacts
12	N.O. Alarm Relay
13	N.C. Form C
14	C. Auxiliary Contacts

Figure 1. Terminal layout:

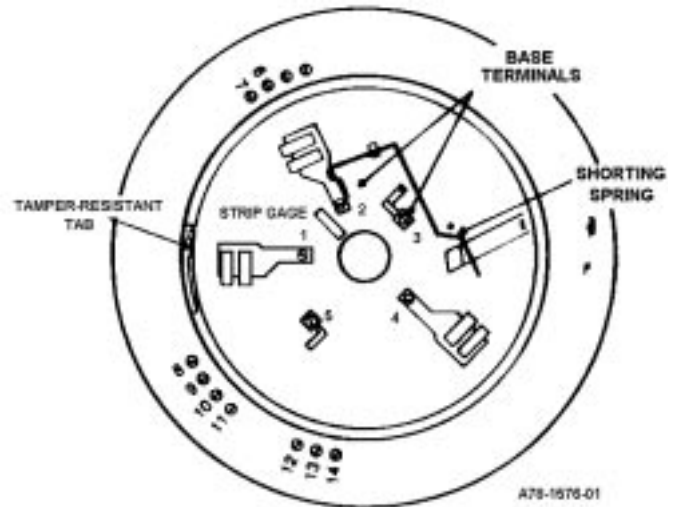

Installation Guidelines

Allowable loop resistance is an important specification for control panels as well as for smoke detectors and their bases. The alarm system cannot be expected to operate correctly if system components have incompatible allowable loop resistances. Therefore, before beginning installation, refer to the control panel manufacturer's loop resistance specification to ensure that it is listed as compatible with the System Sensor base and smoke detector being installed.

All wiring must be installed in compliance with the National Electrical Code and all applicable local codes and any special requirements of the authority having jurisdiction, using the proper wire size. The conductors used to connect smoke detectors to control panels and accessory devices should be color-coded to reduce the likelihood of wiring errors. Improper connections can prevent a system from responding properly in the event of a fire.

For signal wiring (the wiring between interconnected detectors), it is recommended that the wire be no smaller than AWG 18. However, the screws and clamping plate in the base can accommodate wire sizes up to AWG 12. The use of twisted pair wiring for the power (+ and -) loop is recommended to minimize the effects of electrical interference.

Wiring Instructions

NOTE: Refer the manufacturer's instructions for releasing device wiring.

NOTE: To ensure that electrical connections are supervised, do NOT loop wires under terminals 8, 9, 10, and 11 - cut the wire at each terminal.

Figure 2. Mounting base to box:

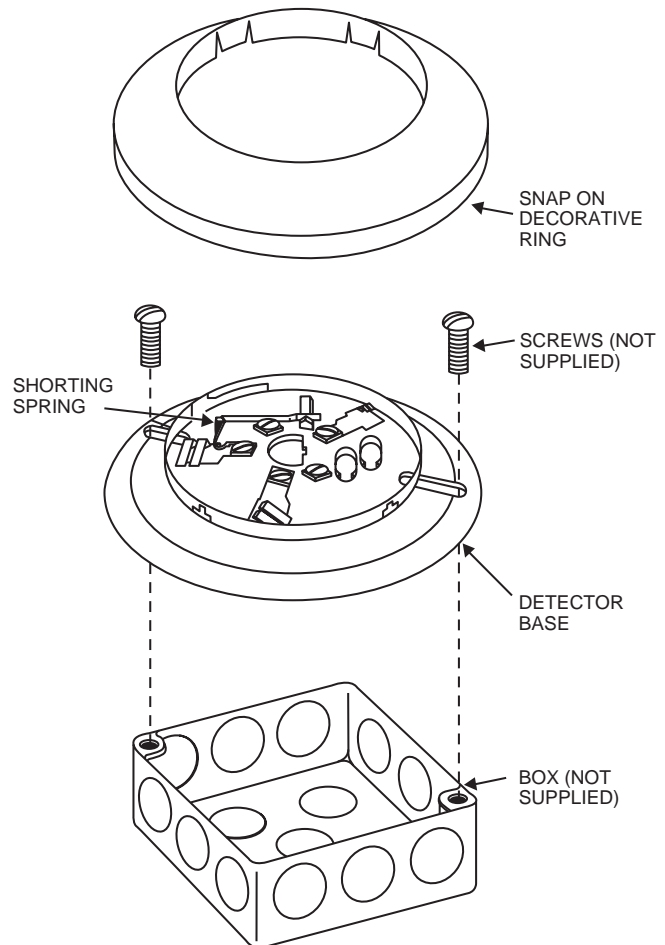

To make electrical connections, strip approximately 3/8" (1 cm) insulation from the end of each wire. Slide a wire under the clamp plate on each side of the terminal screw and tighten the screw.

Figure 3. Wiring diagram for a typical 120VAC detector system:

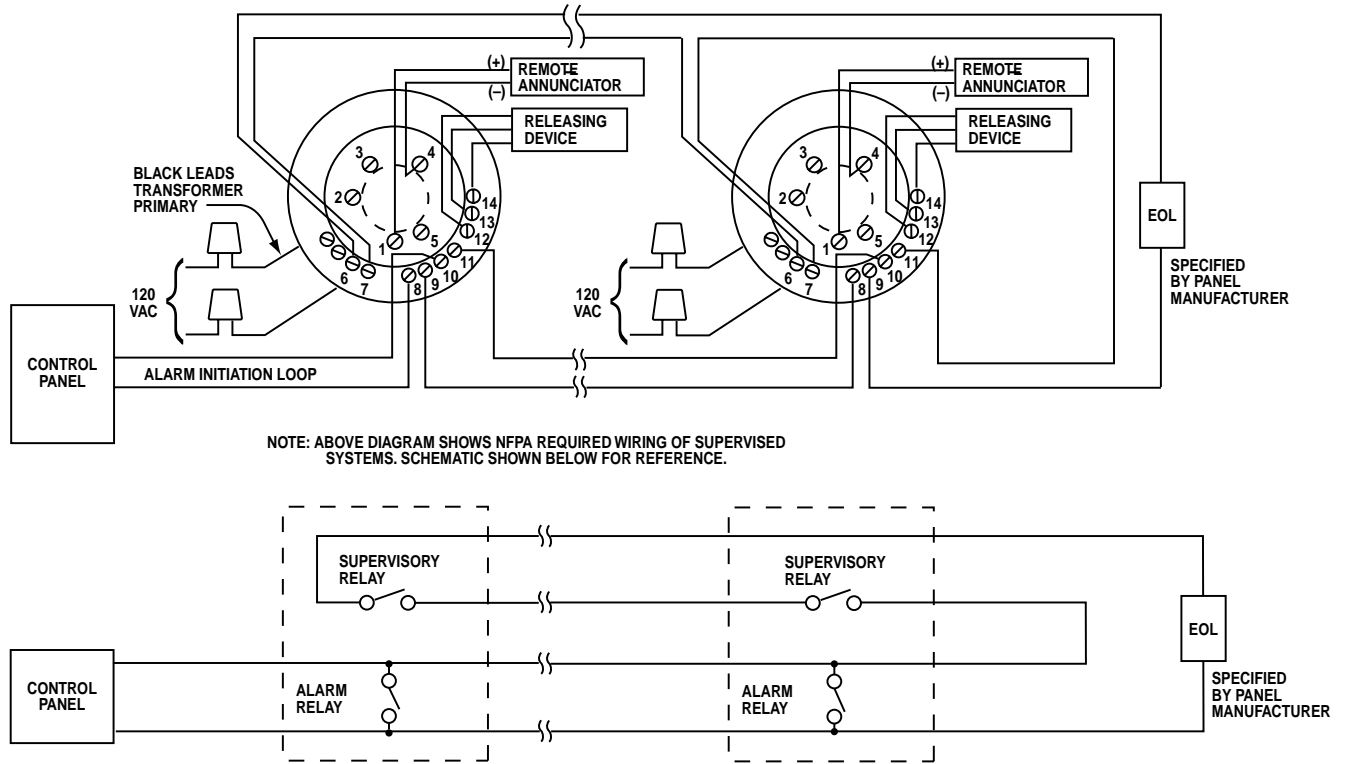

If the base is being installed in a zoned system, check the zone wiring before installing the smoke detector head. The built-in shorting spring makes it convenient to do this. After the detector base is wired and attached to the electrical box, position the shorting spring against terminal 3. Use the slot in the retaining clip to hold the spring against the terminal, as shown in Figure 1. This shorts the negative-in and negative-out leads so that loop wiring can be tested for continuity. Do NOT remove the shorting spring from the base when continuity tests are completed.

After all detector bases have been mounted, wired, and the wiring checked, install the detector heads. The shorting spring in the base automatically disengages when the detector head is removed from the base. DO NOT remove the shorting spring since it reengages as the detector head is turned into the base, completing the circuit.

Tamper-resistance Feature

NOTE: Do NOT use the tamper-resistance feature if the System Sensor XR2 Removal Tool will be used to remove detectors from the base.

This detector base can be made tamper resistant so the detector cannot be detached without the use of a tool. To make the base tamper resistant, break off the smaller tab at the scribed line on the tamper-resistance tab, on the detector mounting bracket (see Figure 4A), before installing the detector.

To remove the detector from the base after it has been made tamper resistant, remove the decorative ring by rotating it in either direction and pulling it away from the base. Then, insert a small screwdriver (Figure 4B) into the notch and press the plastic lever toward the mounting surface. Rotate the detector counterclockwise and remove.

Figure 4A. Activating tamper-resistance feature:

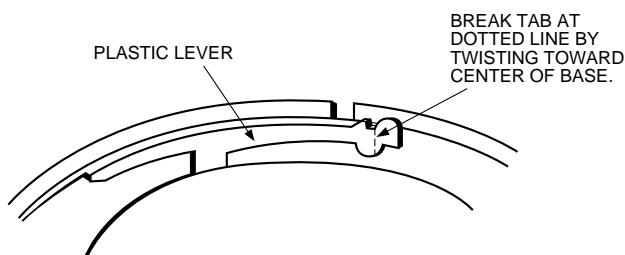
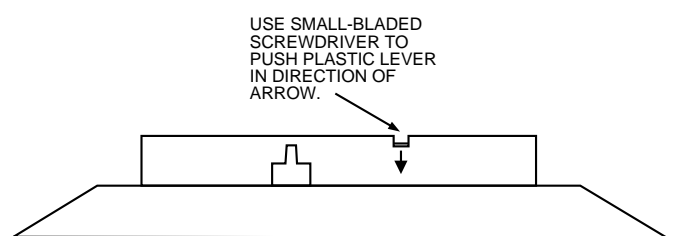

Figure 4B. Removing the detector head from base:



Please refer to insert for the Limitations of Fire Alarm Systems

Three-Year Limited Warranty

System Sensor warrants its enclosed smoke detector base to be free from defects in materials and workmanship under normal use and service for a period of three years from date of manufacture. System Sensor makes no other express warranty for this smoke detector base. No agent, representative, dealer, or employee of the Company has the authority to increase or alter the obligations or limitations of this Warranty. The Company's obligation of this Warranty shall be limited to the repair or replacement of any part of the smoke detector base which is found to be defective in materials or workmanship under normal use and service during the three year period commencing with the date of manufacture. After phoning System Sensor's toll free number 800-SENSOR2 (736-7672) for a Return Authorization number, send defective units postage prepaid to: System Sensor, Repair Department, RA # _____, 3825 Ohio Avenue, St.

Charles, IL 60174. Please include a note describing the malfunction and suspected cause of failure. The Company shall not be obligated to repair or replace units which are found to be defective because of damage, unreasonable use, modifications, or alterations occurring after the date of manufacture. In no case shall the Company be liable for any consequential or incidental damages for breach of this or any other Warranty, expressed or implied whatsoever, even if the loss or damage is caused by the Company's negligence or fault. Some states do not allow the exclusion or limitation of incidental or consequential damages, so the above limitation or exclusion may not apply to you. This Warranty gives you specific legal rights, and you may also have other rights which vary from state to state.